

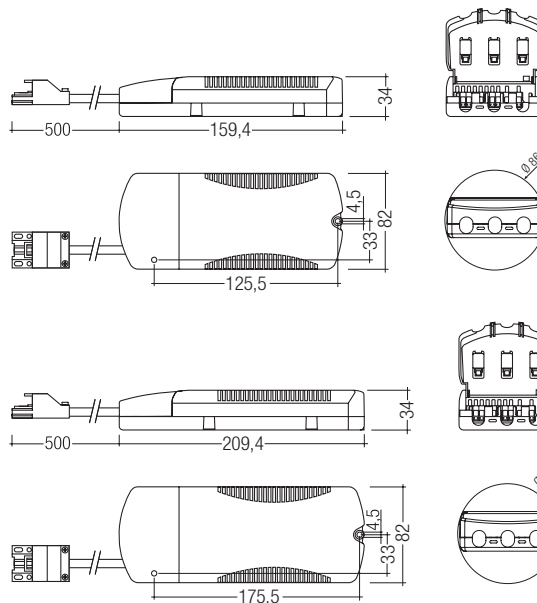

### PCI C521 Single ST PCI PRO, remote applications

#### Product description

- For metal halide lamps
- Also for mobile luminaires with connectors
- Pulse packets for increased ignition energy (pulseCONTROL technology)
- With patented circuit elements
- Halogen-free lamp cable with ST18 socket and interlock lug
- Flicker-free light
- Colour stability thanks to constant power
- Guaranteed long life
- No acoustic resonance
- Safety shutdown if a lamp is faulty or missing
- Greatly reduced reignition time
- Hardly any EMC interference in the ignition phase
- Automatic shutdown on overheating
- Through wiring possible
- No tools required for installing the terminal cover and cable clamps
- Push-in terminals up to 2.5 mm<sup>2</sup>
- 3 separate strain reliefs
- Casing: polycarbonate, black



#### Technical data

Mains voltage range	220 – 240 V
AC voltage range	198 – 254 V
DC voltage range	198 – 320 V
Mains frequency	0 / 50 / 60 Hz
Max. ignition voltage	5 kVp (2 kVp at 22 W)
Operating frequency	145 Hz
Type of protection	IP20



Standards, page 2

Wiring diagrams and installation examples, page 2

#### Ordering data

Type	Article number	Packaging, carton	Packaging, pallet	Weight per pcs.
<b>For luminaires with 1 lamp</b>				
PCI 20 PRO C521 ST	86459019	12 pieces	288 pieces	0.30 kg
PCI 22 PRO C521 ST	86459022	12 pieces	288 pieces	0.30 kg
PCI 35 PRO C521 ST	86458609	12 pieces	288 pieces	0.30 kg
PCI 50 PRO C521 ST	86459309	12 pieces	288 pieces	0.31 kg
PCI 70 PRO C521 ST	86458610	12 pieces	288 pieces	0.31 kg
PCI 150 PRO C521 ST	86458611	12 pieces	288 pieces	0.53 kg

#### Specific technical data

Lamp wattage	Lamp type	Type	Article number	Dimensions L x W x H	Lamp power	Circuit power <sup>Ⓞ</sup>	EEL	Efficiency	Current at 50 Hz 230 V	λ at 50 Hz 230 V	Max. cable length to lamp	tc point max.	Ambient temperature ta	tc/ta for ≥ 50,000 h
<b>For luminaires with 1 lamp</b>														
1 x 20 W	HI	PCI 20 PRO C521 ST	86459019	159.4 x 82 x 34 mm	20 W	23.0 W	A2	> 88 %	0.10 A	0.95	2 m / 160 pF	70 °C	-25 ... +65 °C	70/65 °C
1 x 22 W	HI	PCI 22 PRO C521 ST	86459022	159.5 x 82 x 34 mm	22 W	25.5 W	A2	> 88 %	0.11 A	0.95	2 m / 160 pF	70 °C	-25 ... +65 °C	70/65 °C
1 x 35 W	HI	PCI 35 PRO C521 ST	86458609	159.4 x 82 x 34 mm	39 W	43.5 W	A2	> 89 %	0.20 A	0.97	5 m / 400 pF	80 °C	-25 ... +65 °C	80/65 °C
1 x 50 W	HI	PCI 50 PRO C521 ST	86459309	159.4 x 82 x 34 mm	50 W	55.0 W	A2	> 90 %	0.25 A	0.96	5 m / 400 pF	75 °C	-25 ... +60 °C	75/60 °C
1 x 70 W	HI	PCI 70 PRO C521 ST	86458610	159.4 x 82 x 34 mm	73 W	79.0 W	A2	> 90 %	0.35 A	0.97	5 m / 400 pF	75 °C	-25 ... +50 °C	75/50 °C
1 x 150 W	HI	PCI 150 PRO C521 ST	86458611	209.4 x 82 x 34 mm	147 W	158.5 W	A2	> 91 %	0.70 A	0.97	5 m / 400 pF	80 °C	-25 ... +45 °C	80/45 °C

<sup>Ⓞ</sup> At ta = 25 °C.

**Installation instructions**

**Wiring type and cross section**

Stranded wire or solid wire up to 2.5 mm<sup>2</sup> may be used for wiring. Strip 10–11 mm of insulation from the cables to ensure perfect operation of the screw terminals.

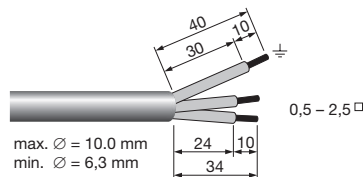

Use one wire for each terminal connector only.

Use each strain relief channel for one cable only.

**Lamp cable connector**

Black ST-18 socket



**Terminals**

Screw type M3  
Torque 0.5 Nm

**Fixing conditions**

Dry, acidfree, oilfree, fatfree. The maximum ambient temperature must not be exceeded. Is not suitable for fixing in corner. Whenever possible keep the ballast away from hot parts. It helps increasing the lifetime of the ballast.

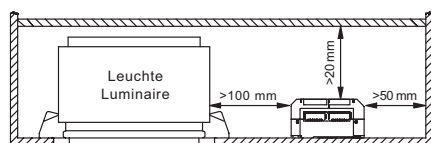

If several ballasts are installed in masts, boxes, etc., measures must be taken to avoid overheating of individual components.

To prevent the use of a wrong lamp type we recommend to mark the luminaire with the correct lamp type that fits to the ballast.

**Note on wiring**

The length of the lamp wires is limited by the value of cable capacitance. The maximum of 160/400 pF would enable connection of approximately 2/5 metres of lamp wire.

In class 1 luminaires it is necessary to earth the ballast and the luminaire, in class 2 luminaires not.

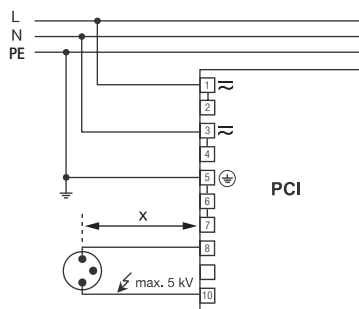

Circuit diagram PCI class 1 application

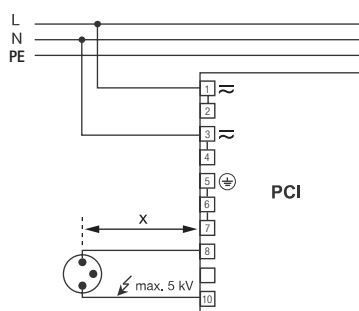

Circuit diagram PCI class 2 application

**Radio interference**

- Do not cross mains and lamp cables.
- Do not lay mains cables together with lamp cables (ideally they should be 5–10 cm apart).
- Do not lead mains cables too closely along the electronic ballast.
- Twist lamp cables.
- Increase the distance between lamp cables and earthed metal surfaces.
- Keep the mains cable short.
- Parallel runs (x) of mains and lamp cables must be kept as short as possible.
- Connection to earth reduces radio interference.

**Important advise**

When a lamp is changed (at the end of its life), if a lamp is missing or after overtemperature shutdown the mains voltage of the ECG must be disconnected.

**Warning – starting voltage up to max. 5 kV!**

Not suitable for use with lamps with integral ignitors.

A list of released lamps for the save operation with PCI can be found on [www.tridonic.com](http://www.tridonic.com) → Technical Data → Lamp matrix → Lamp Matrix for HID

**Safety switch off**

**End of life of the lamps**

At the end of their useful life, lamps often cycle on/off. The PCI ballast recognises this condition and switches off the lamp, after three complete on/off cycles and whilst the supply has been unswitched. Complete lamp switch off enables easy identification of a defective lamp in the application. After a change of the faulty lamp and an interruption of the mains supply (mains reset) the ballast will strike the lamp. When there is no lamp in circuit or a defective lamp is connected to the ballast, the ballast will switch off after apr. 25 minutes.

**Overtemperature shutdown**

The units shut down at Δt approx. +12 °C compared with tc/ta. A mains reset must be carried out so that the units switch on again.

**Overload strength**

320 V<sub>ac</sub> / 1 h  
280 V<sub>ac</sub> / 10 h

**Standards**

- EN 55015 (radio interference)
- EN 61000-3-2 (mains harmonics)
- EN 61347-2-12
- EN 61547 (interference immunity)
- EN 61167

**Glow-wire test according to EN 60598-1**

850 °C passed

**Harmonic distortion in the mains supply**

Type	THD at 230V/50Hz
PCI 20 PRO C521 ST	< 12%
PCI 22 PRO C521 ST	< 12%
PCI 35 PRO C521 ST	< 10%
PCI 50 PRO C521 ST	< 10%
PCI 70 PRO C521 ST	< 10%
PCI 150 PRO C521 ST	< 10%

**Ballast lumen factor EN 60929 8.1**

Type	AC/DC-BLF at U = 198–254 V, 25 °C
PCI 20 PRO C521 ST	1.00
PCI 22 PRO C521 ST	1.00
PCI 35 PRO C521 ST	1.00
PCI 50 PRO C521 ST	1.00
PCI 70 PRO C521 ST	1.00
PCI 150 PRO C521 ST	1.00

### Loading of automatic circuit breakers

Automatic circuit breaker type	C10	C13	C16	C20	B10	B13	B16	B20
Installation Ø	1.5 mm <sup>2</sup>	1.5 mm <sup>2</sup>	1.5 mm <sup>2</sup>	2.5 mm <sup>2</sup>	1.5 mm <sup>2</sup>	1.5 mm <sup>2</sup>	1.5 mm <sup>2</sup>	2.5 mm <sup>2</sup>
PCI 20 PRO C521 ST	30	40	50	60	15	20	25	30
PCI 22 PRO C521 ST	30	40	50	60	15	20	25	30
PCI 35 PRO C521 ST	30	40	50	60	15	20	25	30
PCI 50 PRO C521 ST	14	25	36	42	8	14	18	18
PCI 70 PRO C521 ST	14	25	36	42	8	14	18	18
PCI 150 PRO C521 ST	7	14	20	20	4	6	7	7

### Temperature range

The  $t_a$  temperature value is the basis for specifying the rated life.

The relationship between the  $t_c$  temperature and the  $t_a$  temperature depends on the design of the luminaire. If the measured  $t_c$  temperature is approximately 5 K under the  $t_c$  max. temperature the  $t_a$  temperature should be checked and, if necessary, measurements should be taken on the critical components (e.g. electrolytic capacitor).

Detailed information is available on request.

PCI PRO C521 ST is designed for an average life of 50,000 hours under rated conditions, with a failure probability of less than 10 %. This corresponds to an average failure rate of 0.2 % per 1,000 hours of operation.

The specified  $t_c$  temperature is the maximum permitted value (rated temperature according to EN 61347-1). Above this safety-related value the thermal cutout protects the device against damage. The expected lifetime values are shown in the following table. The  $t_c$  values are the relevant values here.

### Isolation and electric strength testing of luminaires

Electronic devices can be damaged by high voltage. This has to be considered during the routine testing of the luminaires in production.

According to IEC 60598-1 Annex Q (informative only!) or ENEC 303-Annex A, each luminaire should be submitted to an isolation test with 500 V<sub>DC</sub> for 1 second. This test voltage should be connected between the interconnected phase and neutral terminals and the earth terminal.

The isolation resistance must be at least 2 MΩ.

As an alternative, IEC 60598-1 Annex Q describes a test of the electrical strength with 1500 V<sub>AC</sub> (or 1.414 x 1500 V<sub>DC</sub>). To avoid damage to the electronic devices this test must not be conducted.

### Additional information

Additional technical information at [www.tridonic.com](http://www.tridonic.com) → Technical Data

Guarantee conditions at [www.tridonic.com](http://www.tridonic.com) → Services

No warranty if device was opened.

### Expected lifetime

Type	Lamp type	Lamp power	$t_a$	35 °C	40 °C	45 °C	50 °C	55 °C	60 °C	65 °C
				PCI 20 PRO	HI	1x20 W	$t_c$	40 °C	45 °C	50 °C
			Lifetime	> 100,000 h	> 100,000 h	> 100,000 h	> 100,000 h	100,000 h	75,000 h	50,000 h
PCI 22 PRO	HI	1x22 W	$t_c$	40 °C	45 °C	50 °C	55 °C	60 °C	65 °C	70 °C
			Lifetime	> 100,000 h	> 100,000 h	> 100,000 h	> 100,000 h	100,000 h	75,000 h	50,000 h
PCI 35 PRO	HI	1x35 W	$t_c$	50 °C	55 °C	60 °C	65 °C	70 °C	75 °C	80 °C
			Lifetime	> 100,000 h	> 100,000 h	> 100,000 h	> 100,000 h	100,000 h	75,000 h	50,000 h
PCI 50 PRO	HI	1x50 W	$t_c$	50 °C	55 °C	60 °C	65 °C	70 °C	75 °C	x
			Lifetime	> 90,000 h	> 90,000 h	> 90,000 h	90,000 h	65,000 h	50,000 h	x
PCI 70 PRO	HI	1x70 W	$t_c$	60 °C	65 °C	70 °C	75 °C	x	x	x
			Lifetime	> 90,000 h	90,000 h	65,000 h	50,000 h	x	x	x
PCI 150 PRO	HI	1x150 W	$t_c$	70 °C	75 °C	80 °C	x	x	x	x
			Lifetime	100,000 h	75,000 h	55,000 h	x	x	x	x

x ... not permitted

### Storage conditions

Humidity: 5 % up to max. 85 %, not condensed (max. 56 days/year at 85 %)

Storage temperature: -40 °C up to max. +80 °C

The devices have to be within the specified temperature range ( $t_a$ ) before they can be operated.