

Safety Warning



- The installation should be carried out by a qualified electrician in compliance with the current edition of the IEE Wiring Regulations.
- Prior to installation, carry out the necessary risk assessment considering the people who could be at risk, the level of risk and the precautions required to control the risk
- Ensure that the circuit supply is isolated either by the circuit supply fuse being removed or the applicable circuit breaker being turned off before installation or any maintenance.
- Check the total load on the circuit ensuring the luminaire does not exceed the rating of the circuit cable, fuse or circuit breaker.
- Long-term use and voltage fluctuations can reduce the life span of the fitting.
- If the fitting incorporates control gear, ensure careful sizing to avoid instances of nuisance tripping of the protective device used in the installation.
- Follow the provided installation instructions, using the fixings supplied or recommended.
- Keep out of reach of children.



Specification

Box Contents -
1 x IP65 Twin Spot

Dimensions:	H: 288 x W: 300 x D: 69mm
Material:	Polycarbonate
Colour Temperature:	6500K
CRI:	Ra>80
LED Lifetime:	L70B50 36,000 Hrs
IP Rating:	IP65
IK Rating:	IK08
Working Temperature:	0°C to 45°C
Guarantee:	5 Years

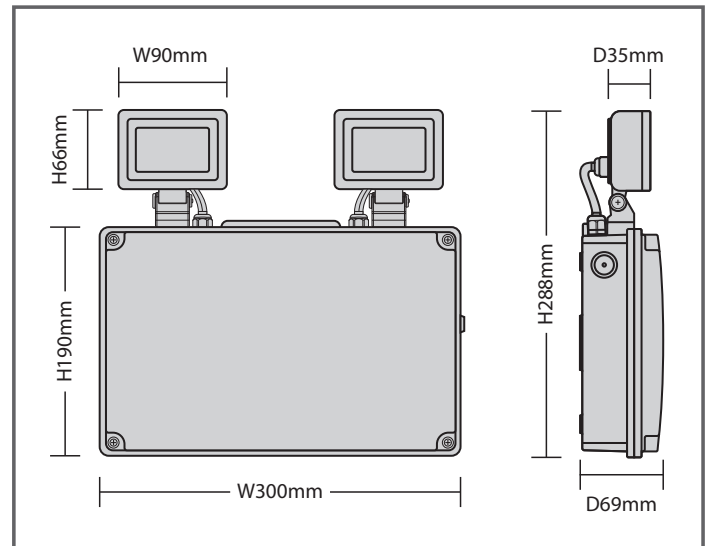

Installation Instructions

1. Isolate the mains supply before carrying out any installation or maintenance work.
2. Remove the front cover from the fitting by loosening the screws at each corner.
3. Drill out the preferred fixing points – the 4 x screw fixing points or central BESA box fixing - and cable entry point, central to the BESA fixing or located on either side of the fitting.

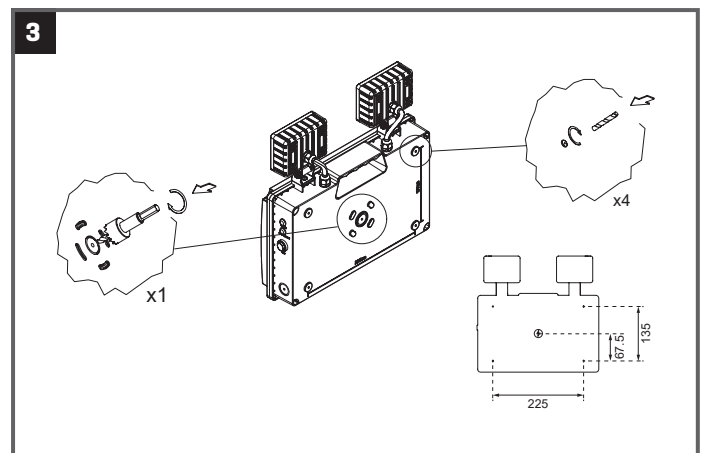
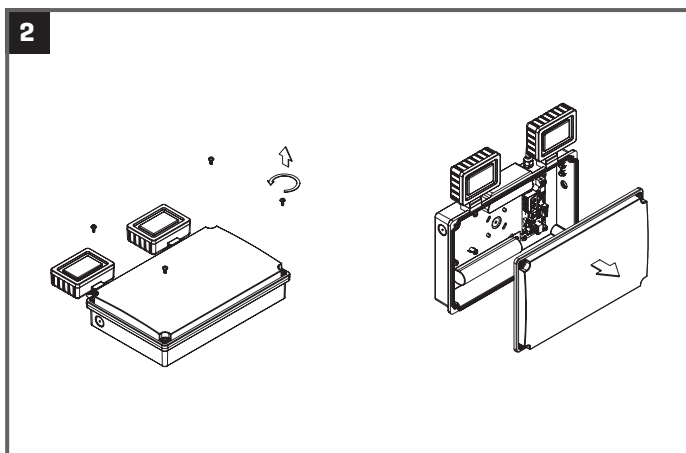

4. Fix the body to the wall in the desired location, passing the supply cable through the cable entry point. Ensure that a suitable cable gland and washers are used to maintain the IP65 rating.
5. Connect the supply cable to the terminal block. An unswitched supply must be connected to the Live (L) and Neutral (N) terminals.
6. Plug the cable from the battery into the white connector on the PCB.
7. Replace the front cover, making sure the screws are fully tightened to ensure a good seal.

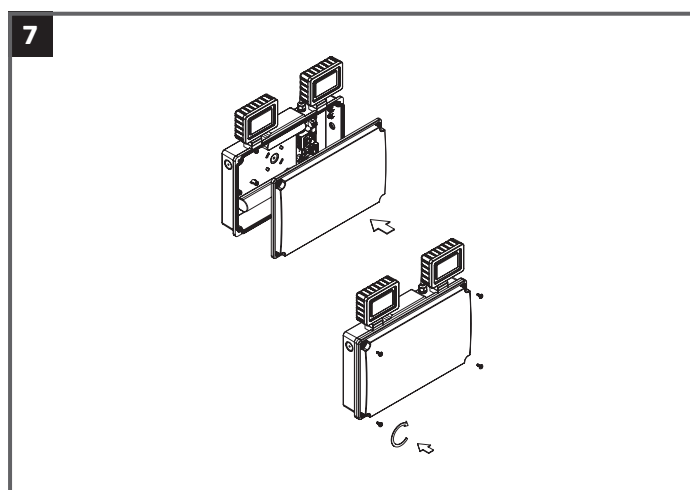
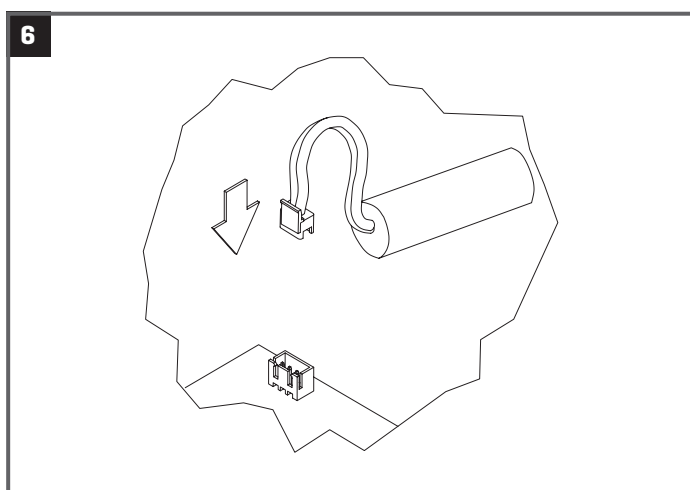
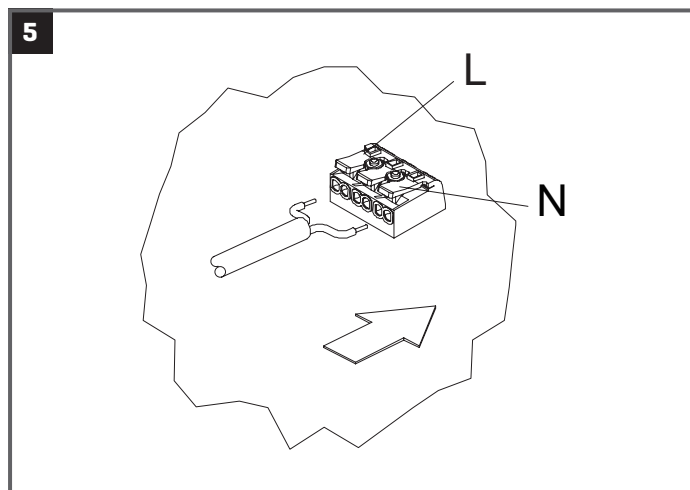
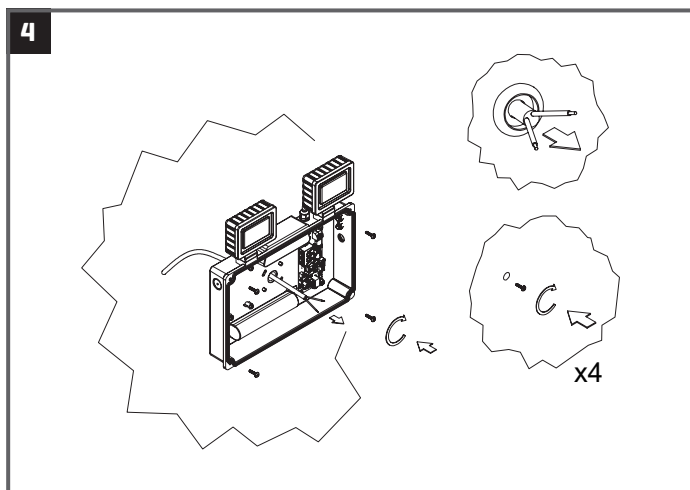

8. Restore the mains supply and check that the green LED indicator (marked charge) is illuminated.
9. Leave the power connected for 24-36 hours to fully charge the batteries and then carry out an emergency commissioning test.
10. The LED heads can be rotated and tilted to the necessary direction and angle to suit the emergency lighting design.

Functions of the LED Indicators

Charge

- Illuminated green under normal, healthy charging mode. If the indicator is not illuminated, the fitting is either in emergency operation mode or it indicates failure of the charging circuit/batteries.

Lamp Healthy

- Illuminated green under normal, LED heads healthy mode. If the indicator is not illuminated, the fitting is either in emergency operation mode or it indicates a fault with one or both LED heads.

Test

- Push button for manual test function.

Operation

Non-maintained

- The LED heads are normally off and the battery on automatic charge (the green LED is on) when the AC Supply is healthy. Solid state circuitry automatically switches the fitting on when the AC Supply is interrupted.

Battery Replacement

If after the routine operation check, the LED heads do not remain lit for the three hour period, a new battery pack may be required.

1. Isolate the permanent live supply.
2. Allow the batteries to fully discharge and then reconnect to the supply and allow to charge for 24 hours.
3. Test again for three hours, if the light does not remain lit change the battery pack as follows:
4. Isolate the mains supply and remove the front cover.
5. Unplug the battery lead from the circuit board.
6. Write the current date on the new battery pack.
7. Fit the new battery pack.
8. Plug the battery back into the circuit board.
9. Replace the front cover.
10. Restore the power and allow to charge for 24 hours.
11. Perform a full operation check and update the test record.

Guarantee

This product is guaranteed for a period of 5 years (batteries 2 years) from the date of purchase. The guarantee is invalid in the case of improper use, tampering, removal of the Q.C. date label, installation in an improper working environment or installation not according to the current edition of the I.E.E. Wiring Regulations (BS7671). The guarantee is also invalidated if the luminaire has been insulation tested. Should this product fail during the guarantee period it will be replaced free of charge, subject to correct installation and return of the faulty unit. We do not accept responsibility for any installation costs associated with the replacement of this product. Your statutory rights are not affected. We reserve the right to alter specifications without prior notice.

Maintenance

- This fitting will require routine cleaning if used in adverse (dust, paint, welding, oils etc) environments. Do not use solvents, aggressive detergents or abrasives.
- The light source & driver in this luminaire can be quickly and easily replaced at end of life. This should be carried out by a competent person. Contact Red Arrow for details of replacements.

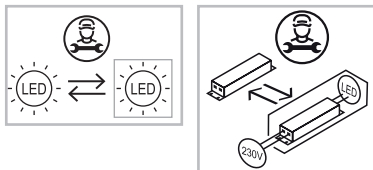

- When this fitting comes to the end of its life or you choose to replace it, please do not dispose of it with your normal waste. Please recycle where the facilities exist, check with your local authority for suitable options.

INS_EMERGENCY_0015_JUNS/500Y_V1

INSTALLATION INSTRUCTIONS

Emergency Testing Sheet

Testing (Emergency Versions)

The emergency lighting must be tested and inspected regularly in accordance with local codes of practice.

NOTE: For safety reasons tests should be carried out preceding time of low risk, to allow for battery recharge.

The minimum recommended test schedule is as follows:

Commissioning - After installation, allow 24 hours to ensure full battery charge, and then interrupt the supply; check after 3 hours that the light is still illuminated.

1. Daily - Check that the charge indicator LED is working.
2. Monthly - Interrupt the power supply for a period sufficient to ensure each light is illuminated. At the end of the test, restore the supply and check the indicator is illuminated.
3. Annually - Interrupt the supply as in 2, but for the full rated duration. Ensure the light is illuminated at the end of the rated duration. Restore the supply and check the indicator is illuminated.
4. Record the date and result of each test, attending to any maintenance required in the event of a test failure.

Luminaire Location

Date Installed

Date Commissioned

Month	Test	Year 1			Year 2			Year 3		
		Signed	Result / Action	Date	Signed	Result / Action	Date	Signed	Result / Action	Date
1	Functional									
2	Functional									
3	Functional									
4	Functional									
5	Functional									
6	Functional									
7	Functional									
8	Functional									
9	Functional									
10	Functional									
11	Functional									
12	Full Duration									