

PLEASE READ THESE INSTRUCTIONS BEFORE COMMENCING INSTALLATION & LEAVE WITH END USER

Description:

The S-HLP/1 kit is a standalone 3 hour non-maintained emergency driver unit suitable for use with a variety of ceiling mounting LED minispot units. The battery is a 3.2V 3.6 Ah Lithium Iron Phosphate (LiFePO4) that enables the driver to provide a 550mA output to the LED emitter in emergency conditions.

The kit is supplied with a choice of differing LED emitters which offer varying outputs and arcs of illumination.

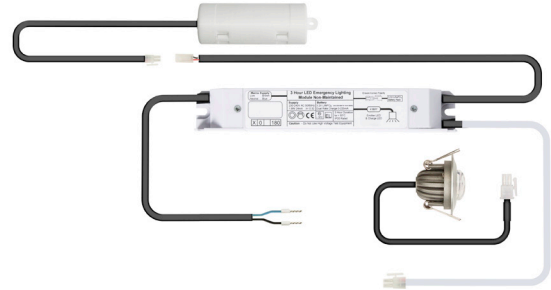

Specification:

Input Voltage	230-240 Volts AC 50/60 Hz
Input Current & PF	11mA - $\lambda = 0.44$
Duration	3 hours
Ambient Temp.	0°C to + 50°C
Max Case Temperature	70°C
Max Battery Temperature	55°C
Mains Input Ferrul Size	0.75mm
Battery Fuse	Internal
Battery Discharge Current	600mA
Discharge Voltage Limit	3.2V
Ingress Protection	IP20
Battery Pack	3.2V 3.6Ah LiFePO4
Charge Current	Dual Rate 0-300mA
Recharge Period	24 Hours
Module Size (L x W x H)	165mm x 26.5mm x 21.5mm
Fixing Centres	157mm
Battery Size (L x Diameter)	240mm x 24mm
Module Weight	0.09Kg
Battery Weight	0.21Kg
LED Weight	0.06Kg

Lumen and Optic Angle

S-HLP/1/40/NL	110 ° Open Area Optic 149 lumen
S-HLP/1/40/OA	110 ° Open Area Optic 161 lumen
S-HLP/1/40/CO	125 ° x 50 ° Corridor Optic 151 lumen
S-HLP/1/41	110 ° Open Area Optic 176 lumen

Important

It is recommended that the remote kit is installed by a competent person ensuring the installation complies with the necessary standards. Liteplan accept no responsibility for injury, damage or loss, which may arise as a result of incorrect installation, operation or maintenance.

The conversion requires an unswitched supply for charging the battery and a switched supply for maintained operation.

ISOLATE BOTH MAINS SUPPLIES AND DISCONNECT THE BATTERY BEFORE INSTALLATION OR MAINTENANCE.

Installation:

1. Cut a 40mm diameter hole in the ceiling tile.
2. Connect the LED Bezel to the main assembly via the 4 way connector.
3. Connect the 2 core cable as follows - Brown Unswitched (Battery Charging) 240V and Blue to Neutral.
4. Only connect the battery when the Un-switched supply is fully assured. Even though these units are protected with a Deep Discharge Protection Circuit, the Batteries can be damaged by being left in an uncharged state for prolonged periods. Ensure correct polarity.
5. When the supply is present and the battery connected, check that the green LED indicator is illuminated showing that the supply is healthy and the batteries are charging.
6. Pass the whole assembly through the 40mm aperture and clip the LED housing into the ceiling.

PLEASE READ THESE INSTRUCTIONS BEFORE COMMENCING INSTALLATION & LEAVE WITH END USER

Typical Wiring Diagram

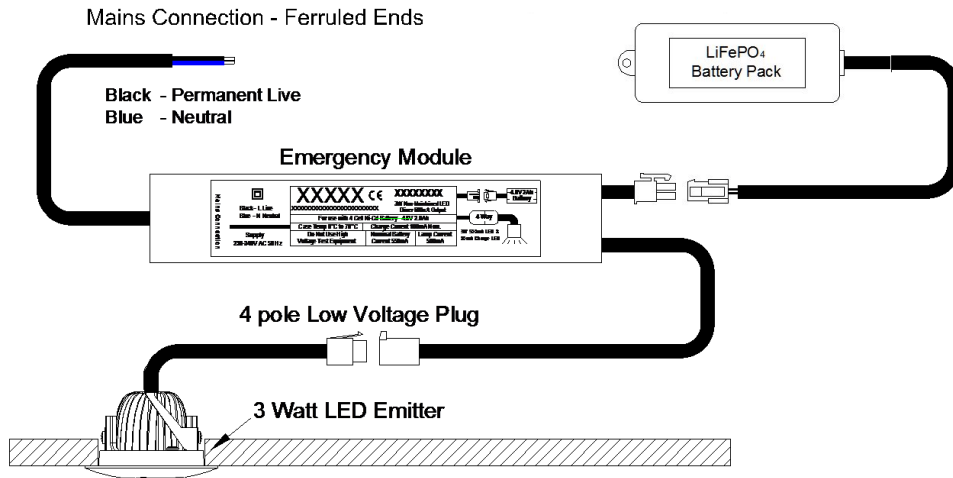

Testing/Commissioning:

- Ensure the Load is connected.
- Connect the battery.
- Switch on the Unswitched Supply - Check the Charge LED illuminates.
- Switch off the Unswitched Supply - Check the Charge LED extinguishes and the load LED illuminates at a reduced output.
- Enter the commissioning date on the Battery Pack.
- Switch on the Unswitched Supply

Luminaire Ref/Location			In Case of difficulty, contact the Installation Engineers:- Tel:							
Full Recharge Time 24 Hours			Duration 3 Hours				Lamp Type - LED			
ROUTINE TEST RECORD										
	Year 1		Year 2		Year 3		Year 4		Year 5	
Monthly Test	Signed	Date	Signed	Date	Signed	Date	Signed	Date	Signed	Date
Functional										
Functional										
Functional										
Functional										
Functional										
Functional										
Functional										
Functional										
Functional										
Functional										
Three Hour										